

# WOLTMAN WATER METER

## Model Turbo-Bar-M

Heavy duty and designed to handle high flow rates, the Turbo-Bar-M Magnetic Drive Water Meter with Magnetic Register covers a very wide flow range, and is particularly suited to industrial, waterworks, water distribution, water monitoring, and Irrigation applications. Based on the Woltman principle, the helical blades of the turbine rotate around the axis of flow, the Turbo-Bar-M is a long-life product, easy to maintain at low cost.

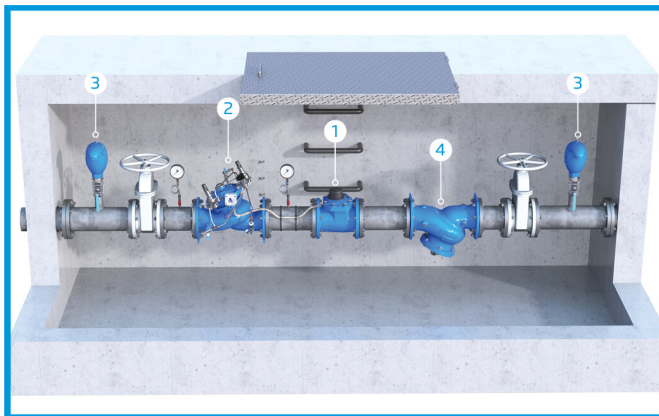

- [1] BERMAD Water Meter Model Turbo-Bar-M
- [2] Pressure Reducing Valve Model 720-45
- [3] Combination Air Valve Model C70
- [4] Strainer Model 70-F

### Features & Benefits

- Magnetic drive
- Dry, IP68; NEMA 6P Sealed Register
- "Reed switch" sensor allow one or two pulse outputs option
- Easy maintenance
- ID 2004/22/EEC Approved, according to OIML R49, EN14154 (sizes 40 - 300 mm)

### Operation:

BERMAD TURBO-BAR with magnetically driven register with high reliability hermetically sealed, the register is separated from the measuring element. Velocity type water meter counting the flow velocity, assuming a line profile full with water at known section.

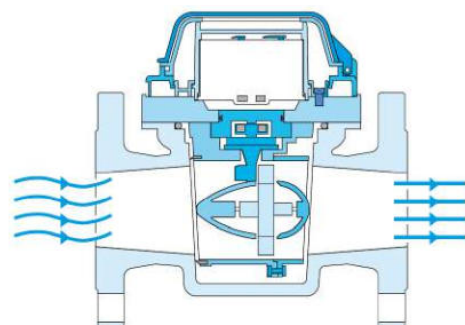

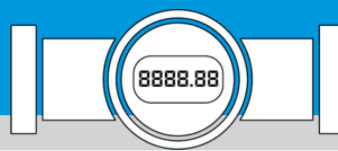

### Turbo-Bar-M

## Technical Data

**Pressure Rating:**  
16 bar

**Operating Temperature:**  
Water up to 50°C

**End Connections - Flanged:**  
ISO PN16

**Materials**

**Body & Cover:**  
Ductile Iron

**Coating:**  
Polyester Blue

## Technical Specifications

For other end connection types,  
Please refer to [BERMAD](#) full engineering page.

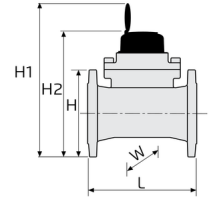

Size (DN)	Pattern	End Connection	Weight (Kg)	L (mm)	H (mm)	H1 (mm)	H2 (mm)	W	KV
1½" ; DN40	Straight flow	Flanged	13	260	170.5	408	336	160	95
2" ; DN50	Straight flow	Flanged	12	200	180.5	347.3	275.3	170	125
2½" ; DN65	Straight flow	Flanged	14	200	190.5	357.3	285.3	190	170
3" ; DN80	Straight flow	Flanged	16	225	200.5	367.3	295.3	200	190
4" ; DN100	Straight flow	Flanged	19	250	215	377.3	305.3	230	280
5" ; DN125	Straight flow	Flanged	20	250	245	392.3	320.3	250	380
6" ; DN150	Straight flow	Flanged	39	300	277.5	436.6	364.6	285	950
8" ; DN200	Straight flow	Flanged	52	350	335	466.6	394.6	340	1580
10" ; DN250	Straight flow	Flanged	105	450	398	584.5	512.5	395	2688
12" ; DN300	Straight flow	Flanged	120	500	452	611.5	539.5	445	4700
14" ; DN350	Straight flow	Flanged	120	500	452	611.5	539.5	445	4700
16" ; DN400	Straight flow	Flanged	187	500	647	731.5	659.5	600	9500
20" ; DN500	Straight flow	Flanged	256	500	784.5	846.5	774.5	700	15000

## Flow Properties

Size (DN)	Accuracy	DN40	DN50	DN65	DN80	DN100	DN125	DN150	DN200	DN250	DN300	DN350	DN400	DN500	
Q @ (m³/h)		1½"	2"	2½"	3"	4"	5"	6"	8"	10"	12"	14"	16"	20"	
Q1 Minimum Flow	±5%	0.5	0.5	0.8	1.3	1.3	2	3.1	5	8	12.5	12.5	32	50	
Q2 Transitional Flow	±2%	0.8	0.8	1.3	2	2	3.2	5	8	12.6	20	20	51	80	
Q3 Permanent Flow	±2%	25	40	63	63	100	160	250	400	630	1000	1000	1600	2500	
Q4 Maximum Flow (Short Time)	±2%	31	50	79	79	125	200	313	500	788	1250	1250	2000	3125	
Q2/Q1		1.6	1.6	1.6	1.6	1.6	1.6	1.6	1.6	1.6	1.6	1.6	1.6	1.6	
Q3/Q1		50	80	80	50	50	80	80	80	80	80	80	50	50	
Max. reading, m³		999,999						9,999,999			99,999,999				
Min. reading, liter		1						10			100				

## Pulse Option

Register Type	Dry contact Reed Switch			
	One pulse per			
Size (DN)	100L	1m³	10m³	100m³
1½"-2½" ; DN40-65	✓	✓		
3"-10" ; DN80-250		✓	✓	
12"-20" ; DN300-500			✓	✓

## Accuracy Curve

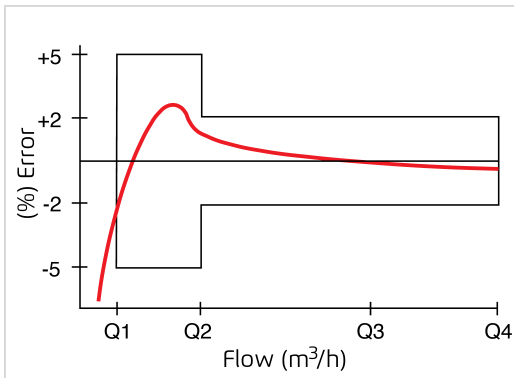

## Flow Chart

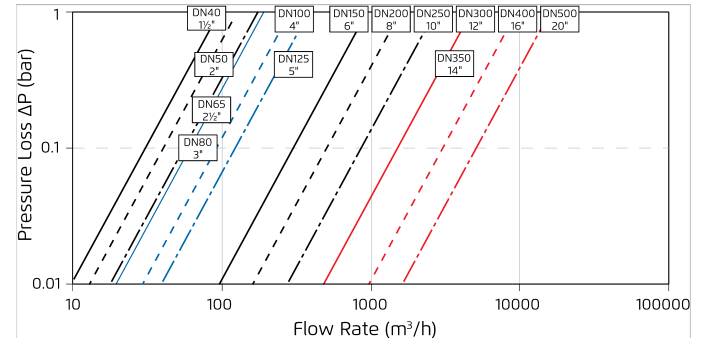

## Differential Pressure & Flow Calculation

$$\Delta P = \left( \frac{Q}{Kv} \right)^2$$

Kv = m³/h @ ΔP of 1 bar  
Q = m³/h  
ΔP = bar



Magnetic Register



Turbo-Bar-M Register

Output Type	
Dry contact output	

Output Cable Characteristic	
Wire	Function
Red	Pulse Out
Black	GND/COMMON

Output Characteristic	
Cable Length - supplied	1.5 meter
Maximum Cable Length	50 meter
Maximum Applied Voltage	24 AC/DC Max
Switch Current	0.01 A max

Display

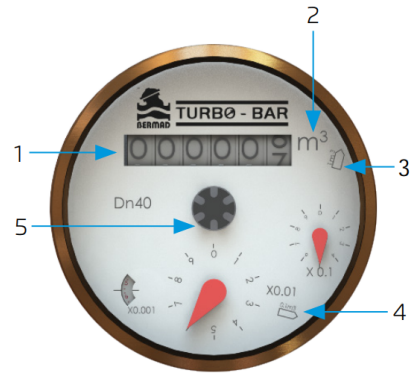

Num	Description
1	Volume
2	Volume units
3	Pulse output #1
4	Pulse output #2
5	Flow indicator

Installation Recommendations

- The water meter can be installed in any orientation without interfering with metrological performance.
- The arrow on water meter body must be in the same direction with the flow.
- To avoid turbulence that may interfere with accurate measurement, it is recommended to have a length of straight pipe equal to 5 diameters upstream from the water meter.
- Prior to installation, flush the line to remove debris.
- The Turbo-Bar must be filled with water to operate.

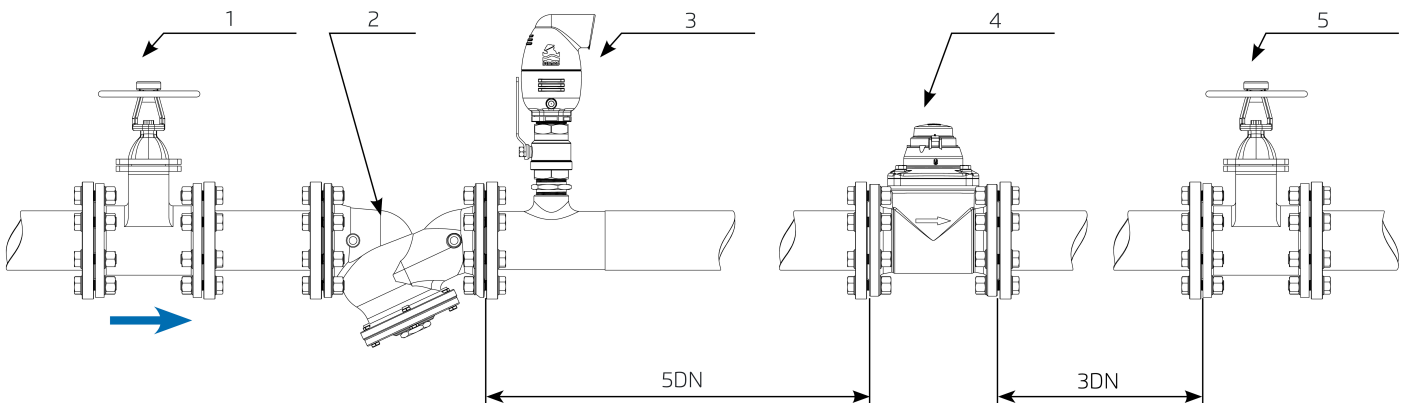
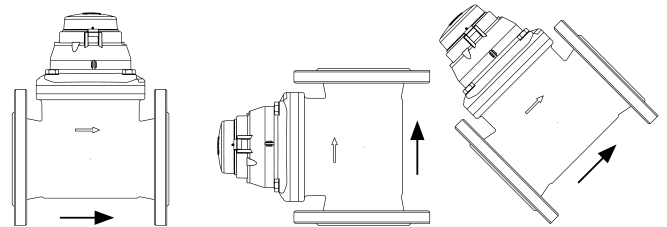

- [1] Isolation Valve
- [2] Strainer
- [3] Air Valve
- [5DN] Unrestricted pipe, minimum 5XDN
- [3DN] Unrestricted pipe, minimum 3XDN
- [4] Turbo-Bar
- [5] Isolation Valve

